

Gas Phase Adsorption of Toluene on Powdered Activated Carbon

Nirbhay Singh Parmar
Department of Civil Engineering,
Rama University Kanpur-209217,
nirbhaysparmar@gmail.com

ABSTRACT

The primary objective was to experimentally determine the performance of powdered activated carbon in effectively adsorbing volatile organic compounds from inert gaseous streams under varying operating conditions. Experiments have been carried out to study adsorption of Toluene (a volatile organic compound) on the powdered activated carbon, using the experimental variables, such as inlet gas concentration (8800 – 19000 ppm), gas flow rate (60 ml/min) and height of the adsorbent bed (2.5-6.5 c m). The breakthrough curves are then drawn between ratios of outlet gas concentration to inlet gas concentration and time for different operating conditions. The breakthrough time increases with increase in bed height and decreases with increase in inlet concentration. Adsorption capacity of powdered activated carbon was also found out under varying operating conditions.

Keywords: Adsorption, Breakthrough curve, Powdered activated carbon, VOCs, Toluene

1. INTRODUCTION

Rapid economic development and urban population growth have triggered a series of challenges to the endeavors of maintaining the clean air. Urban air quality is cause of public concern, largely as a result of instances of smog and health problems. New pollutants are being increasingly recognized. Air pollution sources have grown and so also the pollutants. Some of these have led to the emission of some hazardous air pollutants like volatile organic compounds.

Volatile organic compounds (VOCs) are chemicals that have high vapor pressure exceeding 0.5 kPa at 25°C [1], like benzene, toluene, xylene, formaldehyde and methylene chloride. Major VOC emission sources are automobiles exhaust (45%) followed by industrial sites (41%) and remaining from solid waste disposal and from miscellaneous sources [2]. The acute and chronic effects of VOCs on health and environment include eye irritation, nose irritation, throat irritation, cancer, liver damage and kidney damage. Hence, many VOCs have been identified as toxic and carcinogenic [3,4]. Approximately 235 million tons of VOCs are released per year into the atmosphere by man-made sources [5]. The subject has become important because of the impact on environment and human.

Recommended strategies for reducing organic vapors include product substitution or reformulation, thermal or catalytic incineration and activated carbon adsorption followed by regeneration or catalytic incineration of the highly concentrated stream [6]. The removal of volatile organic compounds commonly performed by adsorption is of great interest for the air quality control. The key parameter in adsorption process is the nature of porous solid medium. A high surface area or high micropore volume can be achieved due to the porous structure of the solid and thus high adsorptive capacity. The breakthrough curve is reflective of the adsorbent performance under dynamic conditions. A relatively larger breakthrough time and gradual increase in the concentration following breakthrough are desirable. In the present study powdered activated carbon has been used as an adsorbent for removal of toluene.

The main objectives of this study include: (1) To design a experimental set-up for the adsorption of VOCs on powdered activated carbon. (2) To obtain breakthrough curves under varying operating conditions such as inlet concentrations and height of the adsorbent bed, and (3) To calculate adsorption capacity of powdered activated carbon under varying operating conditions.

2. EXPERIMENTAL STUDIES

The experiments were carried out with VOC i.e. toluene under varying operating conditions, such as bed height and inlet gas concentration. The materials used in the present study are powdered activated carbon (PAC), Toluene .

2.1 Material

Active carbons are made in particulate form as powders or fine granules less than 1.0 mm in size with an average diameter between 0.15 and 0.25 mm. PAC is made up of crushed or ground carbon particles, 95–100% of which will pass through a designated mesh sieve. Table 1 and 2 shows the characteristics of powdered activated carbon and physical properties of toluene.

Table 1 Characteristics of powdered activated carbon

Properties	Powdered Activated Carbon
Density, g/cm ³	2.1
Bulk density, g/cm ³	0.2 - 0.75
pH,%	0.63 ± 0.01
Moisture %	16.67 ± 0.07

Table 2 Physical properties of adsorbate used for the study

Characteristics	Toluene
Molecular formula	C ₇ H ₈
Molecular weight, g/mol	92
Normal boiling point (°C)	110

2.2 Analytical Methods

Concentrations of VOCs were analyzed by using Netal (model- MICHRO-9100) gas chromatograph equipped with a capillary column type SE-30 of length = 2 m, I.D = 2mm and O.D = 3.175 mm and with a flame ionization detector. The injector, oven and detector temperature were maintained at 200° C, 150° C and 220° C respectively the hydrogen gas was used as the fuel and nitrogen gas used as the carrier gas at a flow rate of 20 ml/min and at a

pressure of 4 kg/cm². All the GC data were stored in a computer using a data station, which is connected to the chromatograph with a software winchrom.

2.3 Calibration Curve

To find out the concentration of VOC from the unknown gas-vapor mixture calibration curve was required. Figure 1 shows the calibration curve for toluene at 40°C and at 1 atm pressure [7]

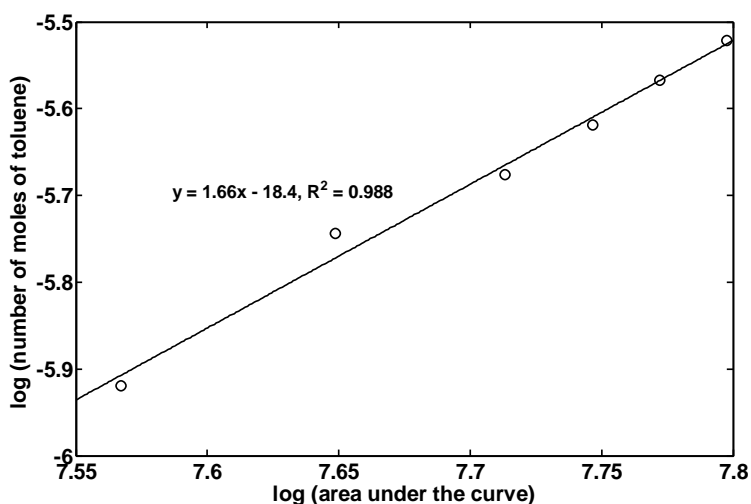

Figure 1: Calibration curve for finding the concentration of toluene vapor in a gas stream at 40° C.[7]

2.4 Experimental Set-up

Figure 2 is the schematic of the experimental set-up designed and used for carrying out adsorption experiments. The set-up consists of three sections; (i) a gas preparation section, (ii) an adsorption section, and (iii) an analytical section. In the gas preparation section, carrier gas (which is nitrogen in this study) is bubbled in the liquid VOC contained in a vertical glass column of (0.7 m height and .05 m diameter). Isothermal conditions are maintained in the column by circulating water at a fixed temperature around the column. The bubbler is made of stainless steel of 6.35 mm diameter tube whose bottom end is closed and the outer surface is

perforated with a hole of diameter .08 mm near the bottom and nitrogen is bubbled in the VOC liquid through the hole. Part of the nitrogen gas at a measured flow rate is bubbled through the VOC liquid and another part of nitrogen is sent directly to the mixing chamber for getting the desired dilution. The resulting gas- vapor mixture from the mixing chamber is sent to the adsorption column of 10 cm height and I.D of 5 cm, filled with an adsorbent with provisions for gas inlet and outlet. The effluent gas stream from the adsorption section is passed to the analytical section consisting of a GC with flame ionization detector (FID) and data section. A computer is connected to the data section to store the peak area. There is a provision of a bypass line for measuring the inlet concentration of toluene through gas chromatograph.

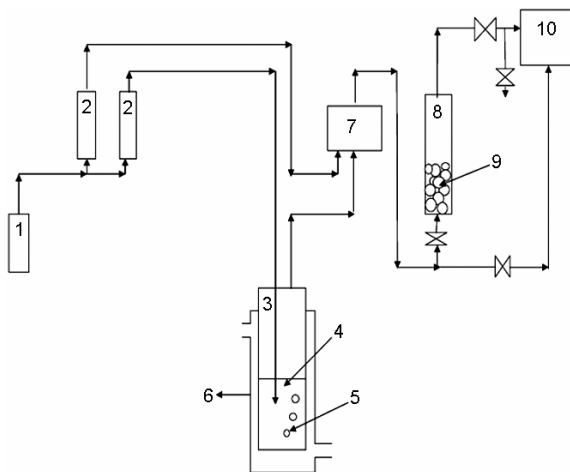

Figure. 2 Schematic diagram of the experimental set-up for xylene adsorption [1 – nitrogen gas cylinder, 2 – rotameters, 3 – VOC glass column with bubbler, 4 – liquid VOC level, 5 – gas bubbles rising through liquid VOC, 6 – jacket for maintaining isothermal conditions, 7 – mixing chamber, 8 – adsorption column, 9 – adsorbent, and 10 – gas chromatography with FID]

2.5 Experimental procedure

Prior to start of the experiments the glass column was filled with a VOC liquid upto a certain height for getting the desired concentration of VOC in a gas vapor mixture. Water bath

circulated at fixed temperature around the column and the sufficient time was given (2 hr) to attain the required temperature. The weighted amount of powdered activated carbon was placed into the adsorption column and supported by a glass wool from both sides to avoid and carryover of adsorbent particles. Nitrogen gas at a measured flow rate is bubbled through VOC liquid and also it was send directly to the mixing chamber for dilution at a fixed flow rate. The concentration of the inlet gaseous mixture is measured by gas chromatograph prior to the start of the adsorption process. It takes around 3- 4 hrs for the inlet gas to reach the steady states and then this gaseous mixture was allowed to pass through the adsorption column. As the adsorption process started, the transient concentrations of exit gas from the adsorption column (breakthrough data) are monitored and measured by a gas chromatograph.

3. RESULTS AND DISCUSSIONS

In this section breakthrough curves have been drawn by conducting adsorption experiments on powdered activated carbon (PAC) under varying operating conditions. Here experiments were carried out under two varying operating conditions i.e. bed height and inlet concentration.

3.1 Breakthrough curve

When the outlet concentration reaches 5% of the initial concentration that time is breakthrough time. The adsorption wave containing a strongly adsorbed solute at concentration C_0 . The fluid is to be passed through a relatively deep bed of adsorbent initially free of adsorbent. The uppermost layer of solid, in contact with the strong solution entering. At first adsorbs solute rapidly and effectively, and what little solute is left in the solution is substantially all removed by the layers of solid in the lower part of the bed. The uppermost layer of the bed is practically saturated, and the bulk of the adsorption takes place over a

relatively narrow adsorption zone in which the concentration changes rapidly, as solution continues to flow, the adsorption zone moves downward as a wave, at a later time roughly half the bed is saturated with solute but the effluent concentration is substantially zero and the lower portion of the adsorbent zone has reached the bottom of the bed and the concentration of solution in the effluent has suddenly risen. The system is said to have reached the breakpoint.

Table 3 lists the values of parameters used in the experiments for the adsorption of toluene. In each case breakthrough time is found out which is defined as time taken for the effluent concentration to reach 5% of the inlet concentration.

Table 3 Parameters used for adsorption experiments.

Parameters	Units	Toluene
Bed height	Cm	2.5,4.5 &6.5
Inlet concentration	Ppm	17000,19000 & 8800
Flow rate	ml/min	60

Adsorption capacities of powdered activated carbon (in mg/gm adsorbent) for toluene under varying operating conditions have been also calculated upto breakthrough time and upto the time experiments were conducted

3.2Effect of bed Height

To determine the effects of bed height on the breakthrough characteristics, the experiments were carried out for varying bed heights at two different bed heights; 2.5 and 6.5 cm. For each run the inlet gas concentration was maintained at 17000 ppm and the gas flow rate was set at 60 ml/min. Here the breakthrough time increased from 70 to 75 minutes, as the bed height was increased from 2.5 to 6.5 cm. As observed from the Figure 3 the breakthrough time and the total adsorption time for toluene increased with increase in bed height. It can be explained in terms of total amount of adsorbent present in the bed. With increase in the bed height which

implies more amount of adsorbent under identical flow rates and inlet gas concentrations the bed will get saturated in a longer time. In other words for the same inlet concentration and flow rate, an increase in bed height results in a longer distance for mass- transfer zone to reach the exit and therefore an increase in the breakthrough time.

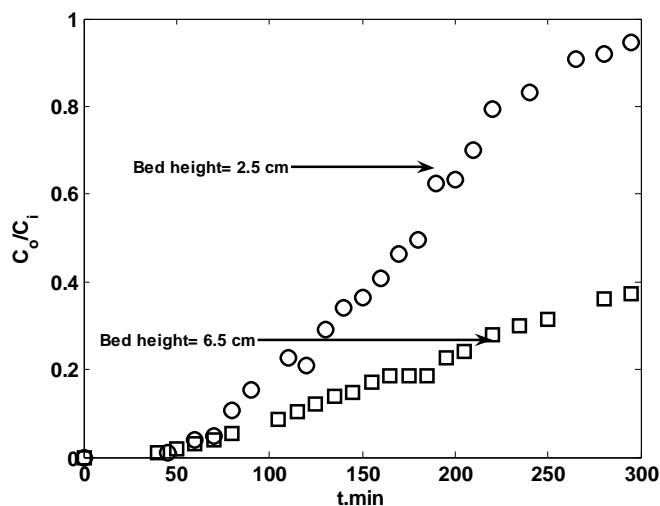

Figure 3: Effect of bed height on breakthrough curve for toluene (inlet concentration = 17000ppm, Flow rate= 60 ml/min).

Table 4 shows the adsorption capacities of powdered activated carbon for toluene upto breakthrough time and upto the time experiments were conducted corresponding to Figure 3

Table 4 Adsorption capacity corresponding to Figure: 3

Sr.No	Bed height(cm)	Adsorption capacity upto breakthrough Time(mg/gm)	Adsorption capacity upto time experiment was conducted (mg/gm)
1	2.5	0.129 mg/gm	0.287 mg/gm
2	2.3	0.477 mg/gm	0.971 mg/gm

3.3Effect of Inlet Concentration

To determine the effect of inlet VOC concentration on the breakthrough characteristics, the experiments were carried out fro varying VOC inlet concentrations; 19000 and 8800 ppm. For each run 4.5 g of the adsorbent was taken and the gas flow rate was set at 60 ml/min. figure

4.5 describes the experimentally obtained breakthrough curves for toluene under the various gas inlet concentration. As observed from figure 4.3 the breakthrough time decreases from 170 to 55 minutes as the inlet concentration was increased from 8800 to 19000 ppm. The experiments were carried out from varying VOC inlet concentrations; 11000 and 17000 ppm. For each run 6.5 g of the adsorbent was taken and the gas flow rate was set at 60 ml/min. Figure 4.3 describes the experimentally obtained breakthrough curves for toluene under the various gas inlet concentration. As observed from figure 4.4 the breakthrough time decreases from 145 to 75 minutes as the inlet concentration was increased from 11000 to 17000 ppm. The effect of inlet concentration on breakthrough curves for toluene has been shown in Figure 4.3, 4.4 by keeping all other parameters identical. It has been observed from Figure 4.3, 4.4 and 4.5 that breakthrough time decreased with the increase in inlet concentration. The total time for the bed to get saturated was also found to be lesser at higher concentrations. The mass transfer zone at higher concentrations will proceed faster than at lower concentrations. As a result, with increasing adsorbate concentration, breakthrough time decreases and the breakthrough curve become steeper and steeper.

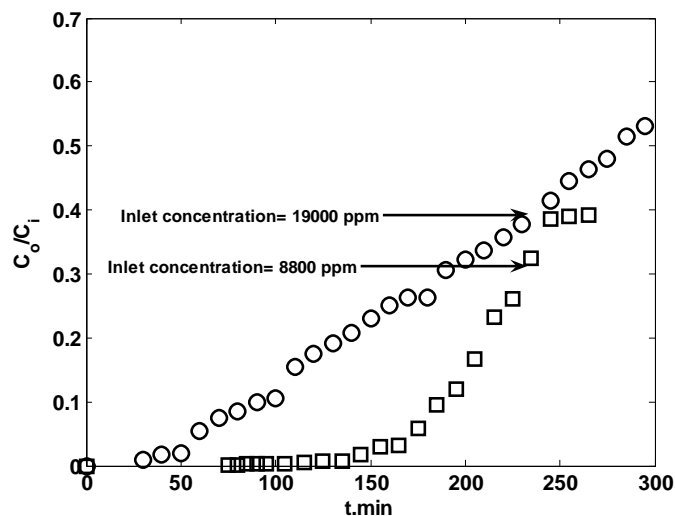

Figure 4 Effect of inlet concentration on breakthrough curve for toluene (Bed height =4.5cm Flow rate= 60ml/min)

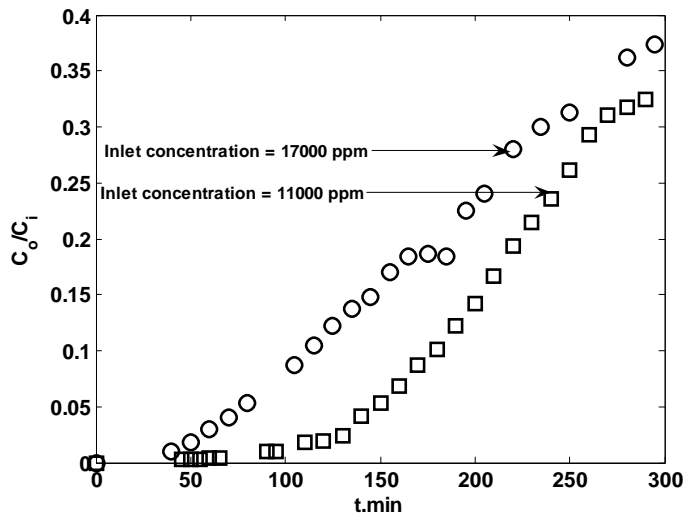

Figure 5 Effect of inlet concentration on breakthrough curve for toluene (Bed height = 6.5 cm, Flow rate=60 ml/min)

Table: 3.3, Table: 3.4 show the adsorption capacities of powdered activated carbon for toluene upto breakthrough time and upto the time experiments were conducted corresponding to Figure 3.2, 3.3

Table: 5: Adsorption Capacity corresponding to Figure 4.3

Sr.No	Inlet concentration (ppm)	Adsorption capacity upto breakthrough Time(mg/gm)	Adsorption capacity upto time experiment was conducted (mg/gm)
1	8800	0.06497 mg/gm	0.7254 mg/gm
2	19000	0.137 mg/gm	6.85 mg/gm

Table 6: Adsorption Capacity corresponding to Figure 4.4

Sr.No	Inlet concentration (ppm)	Adsorption capacity upto breakthrough Time(mg/gm)	Adsorption capacity upto time experiment was conducted (mg/gm)
1	17000	0.1513 mg/gm	0.281 mg/gm
2	11000	0.0675 mg/gm	1.068 mg/gm

4. CONCLUSIONS

Experimental studies have been carried out for the adsorption of the removal of toluene on powdered activated carbon (PAC). The experiments were carried out under various inlet concentrations and varying bed heights following conclusions have been drawn based upon the experimental studies. The experimental studies revealed that powdered activated carbon (PAC) is a potential adsorbent for capturing toluene at low concentration levels due to its high surface area. The breakthrough time during adsorption was observed to considerably decrease with increase in the inlet concentration levels. The breakthrough time during adsorption was found to be increasing with increase in bed height suggesting greater utilization of bed at greater bed heights.

REFERENCES

- [1] Magureanu M, Mandache N B, Eloy P, Gaigneaux E M & Parvulescu V I, *Appl Catalysis B: Environ*, 61 (2005) 12-20.
- [2] Sincero A P & Sincero G A, *Environmental Engineering A Design Approach* (PHI Learning Private Limited, New Delhi), 2011.
- [3] Wu X, Fan Z, Zhu X, Jung K H, Ohman-Strickland P, Weisel C P & Liou P J, *Atmospheric Environ*, 57 (2012) 72-79.
- [4] Lerner J E, Sanchez E Y, Sambeth J E & Porta A A, *Atmospheric Environ*, 55 (2012) 440-447.
- [5] Malley A O & Hodnett B K, *Catalysis Today*, 54 (1999) 31-38.
- [6] Fuertes A B, Marban G & Nevskaya D M, *Carbon*, 41 (2003) 87-96.
- [7] Gupta, K N, *Ph.D. Thesis*, J.U.E.T, Guna, India (2012).